

NORSOK STANDARD

DESIGN PRINCIPLES **CODING SYSTEM**

Z-DP-002
Rev. 3, October, 1996

Please note that whilst every effort has been made to ensure the accuracy of the NORSOK standards neither OLF nor TBL or any of their members will assume liability for any use thereof.

CONTENTS

INTRODUCTION	3
Objectives of the NORSOK Coding System	3
Main Changes from revision 2 to revision 3	3
1 FOREWORD	4
2 SCOPE	4
3 NORMATIVE REFERENCES	4
4 DEFINITIONS AND ABBREVIATIONS	5
4.1 Definitions	5
4.2 Abbreviations	5
5 DOCUMENT CODING	6
5.1 General	6
5.2 Document identification code format	6
5.3 Mandatory attributes	7
5.4 Informative attributes	7
5.5 Manufacturer information	8
6 TAG CODING	8
6.1 General	8
6.2 Main equipment	8
6.3 Piping and valves	8
6.3.1 PIPES AND LINES	8
6.3.2 SPECIAL ITEMS	10
6.3.3 MANUAL VALVES	10
6.3.4 PIPE SUPPORTS	11
6.4 Electrical	11
6.4.1 ELECTRICAL EQUIPMENT RELATED TO TAGGED EQUIPMENT	11
6.4.2 ELECTRICAL FIELD EQUIPMENT NOT RELATED TO TAGGED EQUIPMENT	12
6.5 Instruments & Telecommunication - Field equipment and main control	12
6.6 Cables and junction boxes	12
6.7 Telecom	13
6.8 Fire and gas detection	13
ANNEX A SYSTEM (NORMATIVE)	14
ANNEX B FUNCTION AND TYPE CODES (NORMATIVE)	17
ANNEX C DISCIPLINE CODES (NORMATIVE)	28
ANNEX D DOCUMENT TYPE CODES (NORMATIVE)	29
ANNEX E AREA CODES (NORMATIVE)	31
ANNEX F ACCEPTANCE CODES (INFORMATIVE)	33
ANNEX G PRODUCT SERVICE CODES , INCLUDING COLOR CODING (INFORMATIVE)	34

ANNEX H EXAMPLES (INFORMATIVE)

36

INTRODUCTION

Objectives of the NORSOK Coding System

The coding system has been developed to meet the following main objectives:

- To support the objectives of NORSOK.
- Compliance with the functional NORSOK standards to enable standardised deliveries and transfer of experience.
- To contribute to a quick project initiation and minimum project execution time.
- To ensure common coding for multifunctional teams and multi-skilled personnel.
- To enable and ensure efficient and standardised communication within the petroleum and natural gas industries.
- To support functional breakdown of a facility and related documentation of systems, subsystems and equipment to ensure standardisation and reuse.

Main Changes from revision 2 to revision 3

These are in summary:

- The functional breakdown has been simplified in that the number of levels in breakdown have been reduced; the unit and sub-unit have both been removed from the structure
- In general the identification codes have been tried to be made simpler and less classifying; change to simpler identification
- The documentation identification code has been simplified
- The TAG Code format has been designed to 6 different main types, there is no general coding format covering all main groups
- Association of attributes to the code formats have been made more explicit, more have been made mandatory. The attributes are in general anticipated to be registered as information elements in the information management systems / technical databases
- The definition of systems and subsystems have been revised and made more explicit
- Tag coding of Telecommunication does not have a separate section, but has been included as part of instrumentation
- HVAC is regarded to be as a utility system in general, and a special system
- Documentation codes have been simplified

1 FOREWORD

NORSOK (The competitive standing of the Norwegian offshore sector) is the industry initiative to add value, reduce cost and lead time and remove unnecessary activities in offshore field developments and operations.

The NORSOK standards are developed by the Norwegian petroleum industry as a part of the NORSOK initiative and are jointly issued by OLF (The Norwegian Oil Industry Association) and TBL (Federation of Norwegian Engineering Industries). NORSOK standards are administered by NTS (Norwegian Technology Standards Institution).

The purpose of this industry standard is to replace the individual oil company specifications for use in future petroleum industry developments and operations, subject to the individual company's review and application.

The NORSOK standards make references to international standards. Where relevant, the contents of this standard will be used to provide input to the international standardisation process. Subject to implementation into international standards, this NORSOK standard will be withdrawn.

All annexes except annex F, G and H are normative.

2 SCOPE

This coding system has been developed for tag coding and document coding.

Coding of articles and bulk materials is governed by the NORSOK standard Z-CR-002, Component identification.

3 NORMATIVE REFERENCES

IEC 1346-1	Industrial systems, installations and equipment and industrial products - Structuring principles and reference designations Part 1: Basic rules
ISO 3511	Process measurement control functions and instrumentation - Symbolic representation (NS 1438)
ISO 3511-1	Part 1: Basic requirements
ISO 3511-2	Part 2: Extension of basic requirements
ISO 3511-3	Part 3: Detailed symbols for instrument interconnection diagrams
ISO 8601	Data elements and interchange formats - Information interchange - Representation of dates and times
NEK 606	Cables for offshore installations. Halogen-free, or mud resistant
NORSOK L-CR-001	NORSOK standard - Piping and valves
NORSOK M-CR-501	Surface preparation and protective coating
NORSOK R-CR-004	Piping and equipment insulation
NORSOK Z-DP-001	NORSOK standards and data sheets
NORSOK Z-CR-001	Documentation for operation

NORSOK Z-CR-002 Component identification
 NS 5820 Supplier's documentation of equipment

4 DEFINITIONS AND ABBREVIATIONS

4.1 Definitions

A	Alphabetic character
N	Numeric character
Z	Alphanumeric character
Attribute	Information element that describes a document or tag with further details
Document	A limited amount of information stored on various types of media.
Document id.	A code that uniquely defines a document and follows the document during the document's life cycle.
Facility	A facility consists of functional systems.
System	Functional systems provide services independent of the technology employed.
Subsystem	Subsystems are a break down of systems.
Function & type code	Information elements that describe the function of a specific item.
Tag	A unique code that defines the functional location and function of a physical component within a facility. The "functional location" only refers to where the tag is located within a system, <u>NOT</u> the precise physical position.
Originator	The organisation/contractor/supplier who initially created a document.
Responsible party	The organisation currently responsible for a document, may change over the lifetime of the document.
Shall	Shall is an absolute requirement that shall be followed strictly in order to conform with the standard.
Should	Should is a recommendation. Alternative solutions having the same functionality and quality are acceptable.
May	May indicates a course of action that is permissible within the limits of the standard (a permission).
Can	Can-requirements are conditional and indicate a possibility open to the user of the standard.

4.2 Abbreviations

Achilles	The code of a vendor / company as defined in the catalogue called the Achilles code, maintained by the joint industry company, which is used for vendor information and qualifications
NS	Norsk Standard
IEC	International Electrotechnical Commission
BOP	Blow out preventer
EDP	Electronic Data Processing
GBS	Gravity Base Structure
HVAC	Heating, ventilation and air conditioning

P&ID	Piping and instrumentation diagram
ROV	Remotely Operated Vehicle
UHF	Ultra High Frequency
UPS	Un-interruptable Power Supply
VHF	Very High Frequency

5 DOCUMENT CODING

5.1 General

This section of the Coding System covers the coding of documents used throughout the life of a facility, including technical (engineering and manufacturing), administrative and procurement documents.

A complete document code consists of the document identification code and mandatory attributes.

5.2 Document identification code format

The document identification code structure is:

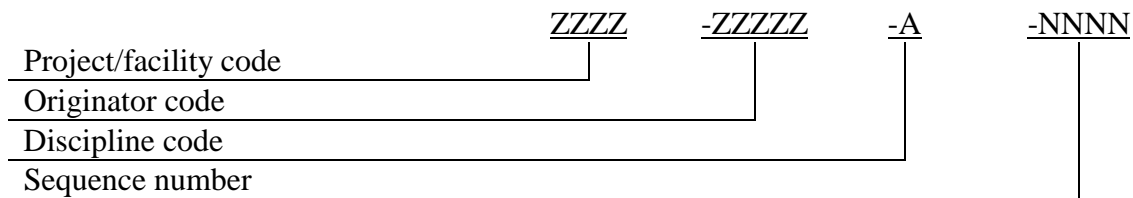

The project/facility code shall be a maximum of four alphanumeric characters.

The originator code is identified by maximum five alphanumeric characters. The originator code shall not be changed, even if the responsibility for the document is changed. The Achilles code should be used as the originator code.

The discipline code is identified by one alphabetic character.

Sequence number shall start from 0001 for each originator, and per discipline. No intelligence shall be included in the sequence number

The project/facility code, originator code, discipline code and sequence number shall be separated by a hyphen (“-”) character. This character shall only be used as a separating character.

Examples: S5-10696-P-0001

A Saga Petroleum project, Achilles code as originator code (Aker Engineering), and first process document.

C010-KE-I-0001

A Phillips Petroleum project, project allocated originator code (Kværner Engineering), first instrument document.

5.3 Mandatory attributes

The mandatory attributes shall be used to enable further detailed description, cross-referencing and presentation.

All mandatory attributes shall be registered in the document information system and shown on the document. When not applicable NA shall be filled in.

The mandatory attributes are:

- System (Annex A)
- Subsystem (Annex A)
- Document Type (Annex D)
- Area (Annex E)
- Title (See below)
- Responsible Party (See below)
- Revision (See below)
- Revision Date (according to ISO 8601, 1988. Example: 19960827)
- Purchase order identification See below
(Only applicable for supplier information)

More than one attribute may be defined. If more than one is defined it shall be registered in document information system.

The title shall describe the content of the document in a concise way, max. 80 characters.

The responsible party code identifies the organisational unit responsible for the document. The responsible party code is identified by up to five alphanumeric characters. The responsible party code shall, at first, be the same as the originator code, but may change during a document's life cycle. For example a document created by an engineering contractor may have its responsibility transferred to a fabricator and later to a hook-up/commissioning contractor. The responsible party code shall be changed in the document information system each time a document is transferred from one responsible party to another. If the document is revised the responsible party code will also be changed on the document as well as in the document information system.

Revision codes. The purpose of the sequential revision number, format NN, is to give each revision a unique identification. The two character sequential number starting at 01 shall be given for the documents first issue and shall be increased with one for each revision.

Purchase order identification may be individually defined.

Example of a completed front sheet and title block with document identification code and mandatory attributes (Annex H)

5.4 Informative attributes

Informative attributes can be defined as necessary.

5.5 Manufacturer information

Manufacturer's documentation shall be identified according to manufacturer's identification system. The Achilles code for manufacturers should be used

6 TAG CODING

6.1 General

The Tag Code is used to identify a function and its logical location within a system.

The Subsystem codes as described in Annex A shall be used a mandatory attributes to the tag coding.

The following main groups of functions are defined:

1. Main equipment
2. Piping and valves
3. Electrical
4. Instruments
5. Cables and junction boxes
6. Fire and gas detection

Each of these groups shall be coded according to its specific syntax.

The specific discipline descriptions are according to international standards where available and when applicable.

6.2 Main equipment

The tag code format for main equipment shall be:

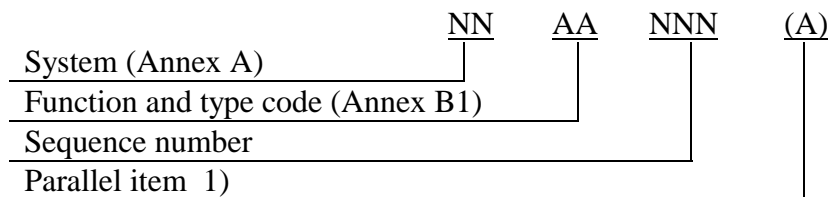

1) Parallel item shall only be used when applicable.

6.3 Piping and valves

6.3.1 Pipes and lines

The tag code format for pipes and lines:

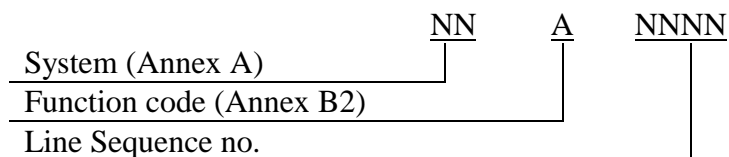

The line sequence no. shall run consecutively within each system.

The line sequence no. shall change as follows:

- at equipment connections
- at tees for non main stream (if not tees for tapping points)
- at line size changes
- at piping class breaks
- at penetration to any monohull
- at module interface

Example: 50L0501
pipe for sea water system

For lines the following mandatory attributes shall be used in computer systems:

- subsystem no., format NN (see Annex A)
- service code, format AA (see Annex G)
- piping class identity, format AANN(A) (ref. NORSOK L-CR-001)
- area code, if passing through several areas, only the area where the main part is or where the starting point of the pipe is , format AZZZ (see Annex E)
- line size format is NNNN; if designed in inches shall be presented as: - 0025 (0,25 in.), 0150 (1,5 in.), 1000 (10 in.), etc., if designed in mm: - 0008, 0025, 0100, etc.
- coating system, format NA (ref. NORSOK M-CR-501)
- insulation class, format NA (ref. NORSOK R-CR-004)
- heat tracing requirement, format A, i.e. Y for yes and N for no

The format for lines on P&IDs, ISO. Drawings and other inspection drawings shall be, and if line lists are used the format shall be :

	<u>NNNN</u>	<u>-AA</u>	<u>-NNLNNNN</u>	<u>-AANN(A)</u>	<u>-NA</u>
Line size					
Service code (Annex G)					
Tag code format for pipes and lines					
Piping class identity					
Insulation class					

Example: 0400-WS-50L0501-AR71-2B
4 inch line size, sea water service code, sea water system, line sequence no. 0501, piping class identity (incl. pressure rating, type of material and sequence no.), insulation class (incl. cold medium conservation and insulation material type for cellular glass).

Insulation and heat tracing is optional, and the format shall be indicated separately on P&IDs as shown below:

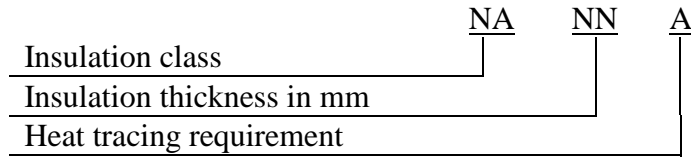

Example: 2B50N

insulation class (incl. cold medium conservation and insulation material type for cellular glass), 50mm insulation thickness, no heat tracing requirements.

6.3.2 Special items

The tag code format for special items shall be:

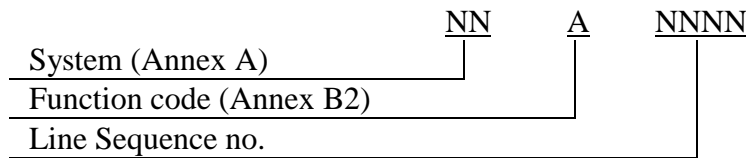

The sequence no. shall run consecutively within each system.

For special items the following mandatory attribute shall be used in computer systems:

- subsystem no., format NN (see Annex A)
- data sheet, format AAA-ANN (ref. NORSOK Z-DP-001)

6.3.3 Manual valves

The tag code format for manual valves shall be:

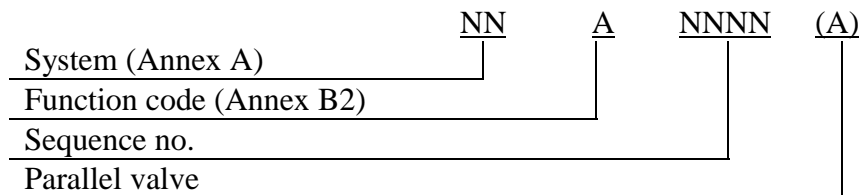

The sequence no. shall run consecutively within each system, function and type code combination.

Manual valve tag code is only entered at a commissioning as-built stage. During design and fabrication the valve data sheet no. according to NORSOK L-CR-001 shall be used.

Example: 40V0035B

cooling medium system, parallel manual valve no. 0035B.

For manual valves the following mandatory attributes shall be used in computer systems:

- subsystem no., format NN (see Annex A)
- valve size in inches or mm, format NNNN, if designed in inches: - 0025 (0,25 in.), 0150 (1,5 in.), 1000 (10 in.), etc., if designed in mm: - 0008, 0025, 0100, etc.

- valve data sheet, format AAAANNA (ref. NORSOK L-CR-001)

6.3.4 Pipe supports

The tag code format for pipe supports shall be:

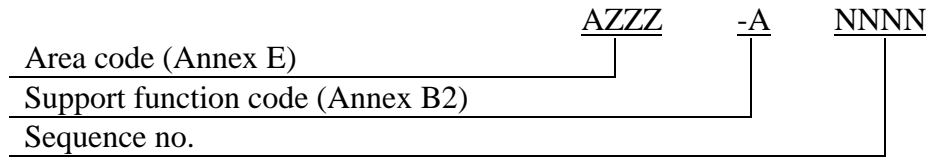

The sequence no. shall run consecutively within each area code and support function code combination.

Example: M12A-S0001

Module 2, level 1, detailed area A, spring pipe support no. 0001.

6.4 Electrical

Electrical equipment shall be tagged according to the sections below.

6.4.1 Electrical equipment related to tagged equipment

The following tag coding is relevant for electrical field equipment which can be associated with a tagged equipment such as process, HVAC equipment or similar. Examples of tagged equipment are pumps, fans, compressors.

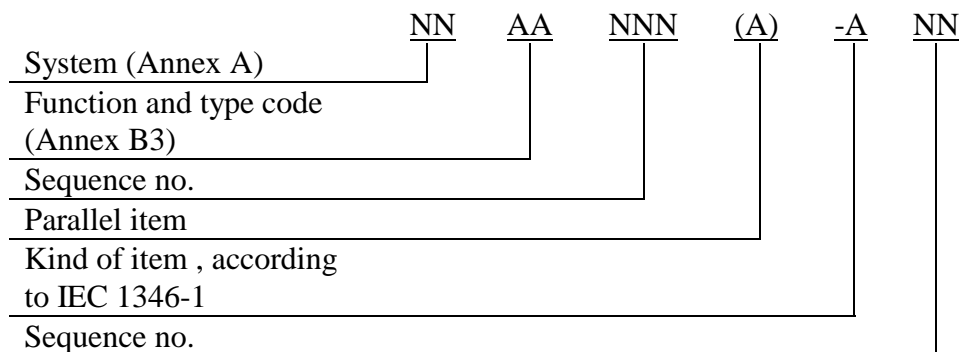

Examples: 27PA001A-M01

Motor number 1 for pump 27PA001A

27PA001A-A01

Starter (Assembly no.1) for pump 27PA001A

27PA001A-A02

Local push button station (assembly no. 2) for pump 27PA001A

6.4.2 Electrical field equipment not related to tagged equipment

The following tag coding is relevant for electrical field equipment which can not be tied to a particular tagged equipment as described in 6.4 or 6.4.1 above. Examples of such are lighting equipment, socket outlets, welding outlets, junction boxes in lighting or heat tracing circuits.

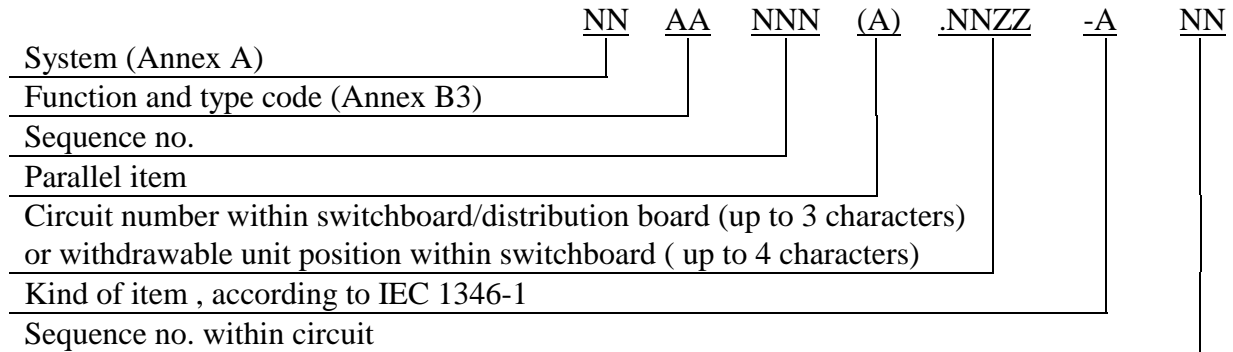

Examples:

82EH008.207-E08

Lighting fixture no. 8 within circuit no. 207 of distribution board 82EH008

82EH008.207-J01

Junction box no.1 within circuit no. 207 of distribution board 82EH008

82EH001A.03AC-X02

Socket outlet no.2 in circuit of unit position 03AC of switch board 82EH001A

6.5 Instruments & Telecommunication - Field equipment and main control

The tag code format for instruments shall be:

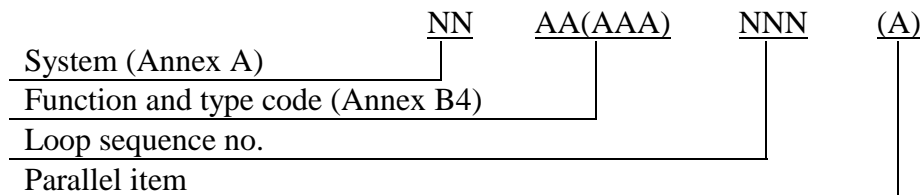

The loop numbering and the use of parallel item shall be according to IEC 1346 - 1

6.6 Cables and junction boxes

The tag code format for cables and junction boxes shall be:

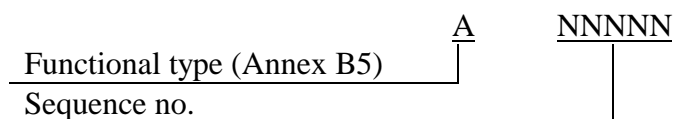

Mandatory attributes for cables:

- Cable type, format AAAA (see NEK 606)
- Number of cores, format NN
- Number of pairs, format NN
- Square sections, format NNN,N (mm²)
- Screen, format A (I=Individual / C=Common)

6.7 Telecom

Telecom shall be coded as instruments.

6.8 Fire and gas detection

The Fire & Gas detectors shall carry an area oriented tag:

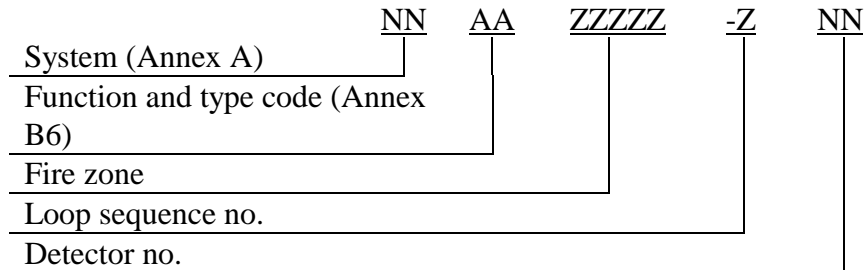

Example: 7D-BF-8102F-B05 Detector number 5 in Loop B, in fire zone 8102, flame detector in the fire and gas detection system.

It is important to number fire zones independently from room numbering since one fire zone can consist of several rooms. The fire zones will be defined in each project by the fire protection philosophy.

ANNEX A SYSTEM (NORMATIVE)

The following main system groups are used.

00-09	Reserved for systems that are specific to a particular plant
10-19	Drilling, well and subsea related systems
20-29	Main process systems
30-39	Export and byproduct handling
40-69	Process support and utility systems
70-79	Safety systems
80-89	Electrical
90-99	Structural, civil, marine and architectural systems

Only defined systems are numbered. Others are vacant and may be defined for each project.

00-09 Reserved to systems that are specific to a particular plant

10-19 Drilling, well and subsea related systems

10	Drilling
11	Drilling process
12	Drilling well control
13	Riser and well topside
14	Drilling control and monitoring
15	Drilling drain
18	Well and riser subsea
19	Subsea installation - maintenance and work over

20-29 Main process systems

20	Separation and stabilisation
21	Crude handling and metering
23	Gas compression and re-injection
24	Gas treatment
25	Gas conditioning
27	Gas export and metering
28	Gas sweetening
29	Water injection

30-39 Export and byproduct handling

30	Oil export line
31	Condensate export line
32	Gas export pipeline
33	Oil storage
34	Injection water pipeline
35	Chemical injection pipeline
36	Wellstream pipeline
37	Gas injection pipeline
38	Glycol / methanol regeneration

39 Loading

40- 69 Process support and utility systems

40 Cooling medium
41 Heating medium
42 Chemical injection
43 Flare
44 Oily water
45 Fuel gas
46 Methanol injection
47 Chlorination
50 Sea water
52 Ballast water
53 Fresh water
55 Steam
56 Open drain
57 Closed drain
58 Thruster and propulsion
61 Jet fuel
62 Diesel oil
63 Compressed air
64 Inert gas
65 Hydraulic power
66 Sewage treatment
69 Lubrication oil

70-79 Safety systems

70 Fire and gas detection
71 Fire water
72 Fire fighting
73 Material handling
75 Passive fire protection
76 Emergency preparedness
77 Environment protection
79 Emergency shutdown and blow down

80-89 Electrical

80 Main power ($u = \text{or} > 6.6 \text{ kV}$)
81 Main power ($1.0 \text{ kV} < u < 6.6 \text{ kV}$)
82 Main power ($u = \text{or} < 1.0 \text{ kV}$)
83 Emergency power ($u = \text{or} > 1.0 \text{ kV}$)
84 Emergency power ($u < 1.0 \text{ kV}$)
85 Battery and no-break
86 Telecommunication
87 Control
88 Earthing and lightning

90-99 Structural, civil, marine and architectural systems

90	Topside structure
91	Sub structure
92	Temporary
93	Architectural incl. Workshop and storage
94	Mooring and positioning
95	Onshore/civil
96	Subsea structure and template
97	HVAC
98	Corrosion protection
99	Area Completion

ANNEX B FUNCTION AND TYPE CODES (NORMATIVE)

International standards are the primary identification principles to be used.

As a supplement for *not defined function and type codes in international standards*, as referenced according to type and function in this appendix, codes as per the following shall be applied as defined below.

The following function and type code classes are defined:

- B.1 Main equipment
- B.2 Piping and Valves
- B.3 Electrical
- B.4 Instruments
- B.5 Cables and Junction boxes
- B.6 Fire and Gas detection

Major function and type codes

A	Architectural
B	Drilling
C	Miscellaneous mechanical
D	Driver and power transmission
E	Electrical
F	Heating, boiling, furnacing and flaring
G	Heating, ventilation and air conditioning (HVAC)
H	Heat transfer
I	Instrumentation
K	Gas compression, blowing and expansion
L	Transferring and controlling
M	Material and product handling
N	Mechanical - solids
P	Pumping
R	Mechanical
S	Safety/escape and fire fighting
T	Telecommunication
U	Subsea
V	Vessel and column - pressurised
W	Wellhead
X	Miscellaneous package units
Z	Storing tanks/containment

B.1 Function and type codes main equipment

These codes are in compliance with the industry coding manual *Standard Cost Coding System - SCCS*.

B Drilling

BA	Derrick
BC	Pipe Handling Equipment
BD	BOP/BOP Accumulator Equipment
BE	Cutting Disposal Package
BF	Mud Burner/Mud Burner Package
BG	Drawworks/Rotary Table and Drawworks Package
BI	Cementing Package
BJ	Top Drive Units/Package
BK	Mud Pump Package
BM	Skid Jacks
BN	Diverters
BP	Drilling Panels
BS	Choke/Production/Injection & Test Manifold
BT	TFL Equipment
BU	Wireline Equipment
BX	Other Drilling Equipment
BY	Hoppers/Mud Guns/Blenders
BZ	Drilling Equipment Packages

C Miscellaneous Mechanical Equipment

CA	Regenerative Filters
CB	Non- Regenerative Filters
CC	Centrifuges
CD	Extractors
CE	Cyclones
CF	Mechanical Separators/Shakers
CG	Refrigeration Units
CH	Chemical Feeders
CI	Molecular Sieves
CJ	Mixers/Agitators
CK	Demisters
CL	Trays
CN	Solid Waste Disposal Units
CP	Incinerators
CQ	Eductors and Ejectors
CR	Trash Racks/Collectors
CS	Lubrication And Seal Oil Units
CT	Hydraulic Units
CU	Comminutors
CV	Trash Stop Gates
CX	Other Miscellaneous Mechanical Equipment
CZ	Miscellaneous Mechanical Equipment Packages

D Drivers and Power Transmissions

DA	Gas Engines
DB	Gearboxes end Couplings
DC	Steam Turbines
DD	Diesel Engines
DE	Electrical Motors
DF	Air Driven Motors/Starters
DT	Gas Turbines
DV	Hydraulic Motors/Starters
DT	Gas Turbines ‘
DV	Hydraulic Motors/Starters
DX	Other Drivers

E Electrical Equipment

EB	Batteries
EC	Control Equipment (Panels, Relay Boxes)
ED	DC Distribution Boards
EG	Generators
EH	Switch gear above 10 k V
EI	Foghorns and beacons (Navigation aid, not telecommunication)
EL	Switch-gear / distribution boards ; U less or equal to 400V
EN	Switch-gear / distribution boards ; U above 400 V , U less or equal to 1 kV
EP	Earthing Bar
ER	Rectifiers, inverters, UPS, frequency converters
ES	Lightning Arrestors
ET	Transformers
EU	Electrical Cathodic Protection
EV	Bus Ducts, Bars and Accessories
EY	Filters and compensation equipment
EZ	Electrical Equipment Packages

F Heaters, Boilers, Furnaces and Flares

FA	Direct Fired Heaters include. Stack and Ducting
FB	Steam Boilers include. Stack and Ducting
FC	Stacked Flares
FD	Flares Ground
FE	Electric Heaters
FF	Special Heaters
FG	Special Boilers
FH	Electrode Boiler Packages
FI	Furnaces
FX	Other Heating, Burning and Boiling Equipment
FZ	Heater, Furnace and Boiler Packages

G Heating, Ventilation & Air Conditioning (HVAC)

GA	Air Handling
GB	Cooling Units, Refrigeration Units
GC	Filters and Filter-Coalesers
GD	Boilers and Heaters
GE	Dampers
GF	Terminal Units
GG	Sound Attenuators
GH	Humidifiers/Dehumidifiers
GI	Air Conditioners
GJ	Heating and Cooling Coils
GK	Fans (Axial/Centrifugal)
GQ	Weather Louvres
GR	Traps
GW	Domestic Water Heaters
GX	Other Heating, Ventilation and/or Air Conditioning Packages

Note! For automatic dumpers, ref. ISO3511

H Heat Transfer Equipment

HA	Shell and Tube Heat Exchangers
HB	Plate Heat Exchangers
HC	Air Cooled Heat Exchangers
HD	Quench Coolers
HE	Misc. Coolers and Condensers
HF	Double Pipe Heat Exchangers
HG	Core Type Heat Exchangers
HH	Liquefaction Heat Exchangers (Cryogenic)
HI	Reboilers/Evaporators
HW	Waste Heat Recovery Units
HX	Other Heat Transfer Equipment
HZ	Heat Transfer Equipment Packages

I Instrumentation

IA	Analysers
IB	Control Panels with Instrument, Controllers, etc.
ID	Navigation Devices
IF	Flow Instruments
IG	Fire & Gas - Shut Down Control System
IH	Oil Metering Packages
II	Gas Metering Packages
IL	Level Instruments
IP	Pressure Instruments
IR	Process Control and Supervisory System
IT	Temperature Instruments
IU	Dynamic Positioning Control System. (DP)
IV	Weight Scales
IW	Emergency Shut-Down System

IX	Other Instrument Equipment
IY	Vibrating/Displacement Measuring Systems
IZ	Instrument Equipment Packages
K	Compressors, Blowers and Expanders
KA	Centrifugal Compressors
KB	Reciprocating Compressors
KC	Screw/Rotary Compressors
KD	Axial Compressors
KE	Fans
KF	Blowers
KH	Expanders
KX	Other Compressors, Blowers and Expanders
KZ	Compressor, Blower and/or Expansion Packages
L	Transfer and Control Equipment
LA	Emergency Shutdown Valves
LC	Major Control Valves
LD	Slug Catcher
LE	Pig Launchers/Pig Receivers
LF	Expansion Joints/Expansion Bellows
LG	Production Risers
LH	Injection Risers
LM	BuBuoyancy Elements/Modules
LN	Intelligent Pigs
LO	Sealing Pigs
LP	Batch Pigs
LQ	Scraper Pigs
LR	Welding Bladders
LS	Pipeline Inspection Tools
LT	Pipeline/Umbilicals End Fittings
LU	Hydraulic Umbilicals
LV	Electrohydraulic Umbilical
LW	Integrated Service Umbilical
LX	Other Transfer and Control Equipment
M	Material and Product Handling
MA	Pedestal Cranes
MB	Hoists and Trolleys
MC	Elevators and Lifts
MD	Trucks, Carts, Forklifts, etc.
ME	Mobile Cranes
MF	Overhead Cranes
MG	Railroad and Road Loading Equipment
MK	Winches
MQ	Packing, Calibrating and Measurement Equipment
MR	Winches
MU	Product Loading and Vapour Return Arms

MV Gantry and Portal Cranes
MX Other Material and Product Handling Equipment
MZ Material and/or Product Handling Equipment Packages

N Mechanical Equipment Solids

NA Belt Conveyors
NB Bucket Elevators
NC Screw Conveyors/Feeders
ND Tube & Flow Conveyors
NE Multi-Flow Conveyors
NF Jaw Crushers
NG Impact Breakers
NH Twin Rotor Impactors
NI Granulators
NJ Gravity Impact Crushers
NK Hammermills
NL Reversible Impactors
NM Roll Crusher
NN Mills
NO Vibrating Packers
NP Vibrating Screens
NR Fines Stifiers & Screens
NS Blenders
NT Bin Activators
NU Feeders

P Pumps

PA Centrifugal Pumps
PB Reciprocating Pumps
PC Rotary Pumps
PD Special Metering Pumps
PE Gear Pumps
PF Diaphragm Pumps
PG Screw Pumps
PH Submerged Pumps with Non-Submerged Motors
PS Submerged Pumps with Submerged Motors
PX Other Pumps

R Telecommunication

RA Public Address and Alarm System
RB SOLAS/GMDSS Radio and General Radio System
RC Closed Circuit Television System - (CCTS)
RD Drillers Talk-Back System
RE Entertainment System
RF Distribution Frames
RG Emergency Telephone
RH Office Intercommunication System
RN Navigation, Positioning and Distance Measuring

RP	PABX System (include. Telephone)
RQ	Data Communication Network
RR	Radar System, Marine and Aviation
RS	Satellite Communication System
RT	Telemetry System
RU	UHF/VHF Radio (Onboard)
RV	Personnel Registration/Paging/Tracking system
RW	Environment Monitoring System
RX	Other Telecommunication Equipment
RZ	Telecommunication Equipment Packages
S	Safety/Escape and Fire fighting
SA	Lifeboats and Davits
SB	Pick- Up Boats and Davits
SC	First-Aid Equipment
SD	Life Saving/Escape Devices
SF	Ambulances
SG	Fire trucks
SH	Inert Gas Equipment
SJ	Fixed Foam Unit
SK	Dual Agent Unit
SL	Dry Chemical Equipment
SM	Fire Water System Equipment
SN	Remote Operated Foam Monitors
SP	Fire Extinguishers
SQ	Hose Reels
SR	Hydrants
SS	Fire Water Monitors(Towers)
SU	Sprinkler/Deluge Systems
SW	Rafts
SX	Other Safety, Escape and Fire fighting Equipment
SY	Central Fire Point Units
SZ	Safety, Escape and/or Fire fighting Equipment Packages
T	Storage Tanks / Containment Equipment - Atmospheric
TA	Storage Tanks - Cylindrical
TB	Storage Tanks - Rectangular
TE	Hoppers
TF	Mud Pits
TG	Sumps
TJ	Bins
TK	Containers
TR	Refrigerated Storage Tanks
TX	Other Tanks
U	Subsea Equipment
UA	Wellhead and Tubing Hanger System
UB	X-mas Tree System

UC	Flow Control
UD	Subsea Station Structure Appurtenances
UE	Lifting, Levelling and Piling System
UF	Pull-in and Connection Structural Equipment
UG	Manifold Valves
UI	Pigging Facilities
UJ	Connection Equipment
UK	Topside Control Equipment
UL	Uninterruptable Power Supply
UM	Hydraulic Power Unit
UN	Subsea Control Pod
UO	Electrical Distribution System
UP	Riser System
UQ	Workover Control System
UR	Intervention System and Tools(ROT)
US	ROV/ROMV and Tools
UT	Intervention Control System
UU	Test Equipment
UX	Special Subsea Equipment
UZ	Other Subsea Equipment
V	Vessels and Columns-Pressurised
VA	Separators
VB	Contractors
VC	Regenerators
VD	Settling Drums, Knock-Out Drums and Flash Drums
VE	Columns/Towers
VF	Reactors
VG	Scrubbers
VH	Deaerators
VJ	Coalescers
VK	Dryers
VL	Receiver and Surge Drums, Expansion-Head Tanks
VP	Gas Holders
VQ	Spheres
VS	Tote Tanks
VT	Oxygen Units
VU	Hydrogen Units
VV	Inert Gas Units
VW	Condensate Control Drums
VX	Other Vessels and Columns
VZ	Vessel-and Column Packages
W	Wellhead Equipment -(Surface Completion)
WA	X-Mas Tree
WB	Tubing Shear Ram
WC	Tubing Shear Ram/X-Mas Tree-Extensions
WD	Wellhead

WE	Wellhead Housing & Extension
WF	Conductor Housing & Extension
WG	Conductor Guides & Hub Connectors
WH	Casing Hanger
WI	Tubing Hanger
WJ	Seal Rings/Seals
WK	Guide Base
WL	Landing Base
WM	Diverter System
WN	Blow Out Preventer Stack
WO	Hydraulic Connectors
WP	Wireline Unit/Wireline Equipment
WQ	Wireline Pressure Retaining Equipment
WX	Other Wellhead Equipment

X Miscellaneous Package Units

XA	Oily Water Treatment Packages
XB	Centrifuge Packages
XC	Inert Gas Generator Packages
XD	Fire Water Pump Packages
XE	Potable Water Pump Packages
XF	Sewage/Waste Water Treatment Packages
XG	Catalyst Packages
XH	Helicopter Fuel Packages
XI	Cooling Towers
XJ	Vacuum Units Packages
XM	Main Power Generator Sets
XN	Emergency Power Generator Sets
XP	Thruster Packages
XQ	Chemical Treatment Packages
XR	Thruster Packages
XQ	Chemical Treatment Packages
XR	Chemical Injection Packages
XT	Compressors/Gasturbine Driver Sets
XV	Instrument Air Packages
XX	Other Equipment Packages
XY	Nitrogen Generation Packages
XZ	Oxygen Generation Packages

Y Mooring & Marine Equipment

YA	Tethers/Tendons
YB	Tether Couplings
YC	Cross-Load Bearings
YD	Tensioner/Motion Compensator
YE	Tether Tie- Off Assembly
YF	Torque Tools
YG	Tether Handling Equipment
YH	Anchor Latches

YI	Tether Deployment Tools
YK	Capstans
YL	Cables & Chains
YM	Anchors
YN	Clump Weights
YO	Fenders
YP	Anchor Pendant Buoys
YQ	Signal Buoys
YR	Mud Mats
YS	Levelling Systems
YT	Remote Operated Vehicles (ROV)
YU	Tank Cleaning/Crude Oil Washing
YV	Accommodation Ladders/Gangways
YW	Turret Equipment
YX	Other Mooring & Marine Equipment

B.2 Function codes piping and valves

Pipes

L	Pipe
---	------

Valves and special items function codes

C	Check valve
S	Special item
V	Manual valve

Support function codes

A	Anchor
G	Guide
H	Holddown
J	Adjustable
L	Linestop
R	Rest
S	Spring

B.3 Function and type codes electrical

The following codes are used for main electrical equipment. Field equipment item designation shall be in accordance with IEC1346 Part I.

EB	Battery
EC	Control equipment/interface panel
EG	Generator
EH	Switch gear/switchboard/distribution board ≤ 400 V
EI	Navigation aid
EL	Switch gear/switchboard > 1 kV
EN	Switch gear/switchboard > 400 V ≤ 1 kV

ER	Resistor
ET	Transformer
EU	Rectifier and inverter, frequency converter
EW	Earthing bar, bus bar/bus duct
EZ	Filters and compensation equipment

B.4 Function and type codes instruments

Function and type codes for instruments shall be according to ISO 3511.

B.5 Functional types cables and junction boxes

C	Control and safety cables
J	Junction boxes (Instruments and telecom)
P	Power cables
T	Telecom cables

B.6 Function and type codes fire and gas detection

AB	Gas detector point (flammable gases)
AI	Gas detector indicator remote or local
AL	Gas alarm light in matrix
AR	Gas detector beam receiver
AS	Gas detector point (Toxic gases)
AT	Gas detector beam transmitter
BA	Addressable unit
BE	Early smoke detector
BF	Flame detector
BH	Heat detector
BI	Fire detector indicator remote or local
BL	Fire alarm light in matrix
BM	Manual fire alarm
BS	Smoke detector
CA	Agent pre discharge alarm/siren
CB	Agent extinguisher predischage beacon
CI	Agent extinguisher indicator/Status light
CL	Agent extinguisher status light matrix
CR	Agent extinguisher release field or matrix
DR	Door release
EL	Emergency shutdown status light matrix
ER	Emergency shutdown manual local reset
ES	Emergency shutdown and isolation switch
ZL	Fire damper position status light matrix

ANNEX C DISCIPLINE CODES (NORMATIVE)

The discipline code is included in the documentation identification and it consists of one alphabetic character.

A	Administration
B	Procurement
C	Civil/architect
D	Drilling
E	Electrical
F	Project control/cost/economy
G	Geology
H	HVAC
I	Instrumentation/metering
J	Marine operation
K	Inspection
L	Piping/layout
M	Material technology
N	Structural
O	Operation
P	Process
Q	Quality management
R	Mechanical
S	Health, safety and environment (HSE)
T	Telecommunication
U	Subsea
W	Weight control
X	Reservoir
Y	Pipeline
Z	Multidiscipline

ANNEX D DOCUMENT TYPE CODES (NORMATIVE)

Ref. to Z-CR-001, Annex A (Document type codes may be used for other documents than those listed in Z-CR-001)

		Ref. to Z-CR-001
AA	Accounting/Budget	
CA	Analysis, test and calculation	A30, A39
DS	Data sheets	A25
FD	Project design criteria and philosophies	A3
KA	Procedures	
LA	List / Registers	A1, A8, A11, A12, A13, A14, A15, A16, A17, A18, A19, A20
MA	Equipment user manual (ref. NS5820)	A5
MB	Operating and maintenance instructions	A5
MC	Spare parts list	A5
PA	Purchase orders	
PB	Blanket order/frame agreement	
PD	Contract	
RA	Reports	A9, A10
RD	System design reports and system user manuals	A4
RE	DFI (Design - Fabrication - Installation) resumes	A7
SA	Specifications & Standards	A2
TA	Plans/schedules	A39
TB	Work plan	
TE	Estimates	
TF	Work package	
VA	Manufacturing/Fabrication and verifying documentation, including certificate of performance, material tractability, weld and NDE documents, list of certificates, third party verification/certificates and photos of submerged structures/equipment	A6
VB	Certificates	A6
XA	Flow diagrams	A21
XB	Pipe and instrument diagram (P&ID)	A22

XC	Duct and instrument diagrams (D&ID)	A23
XD	General arrangement	A26
XE	Layout drawings	A27
XF	Location drawings (plot plans)	A28
XG	Structural information; including main structural steel, secondary/outfitting steel, structural fire protection and acoustic/thermal insulation and fire protection	A29
XH	Free span calculation	A30
XI	System topology and block diagrams	A31
XJ	Single line diagrams	A32
XK	Circuit diagrams	A33
XL	Logic diagrams	A34
XM	Level diagrams	A35
XN	Isometric drawings, including fabrication, heat tracing, stress and pressure testing	A24
XO	Piping supports	A40
XQ	Pneumatic/hydraulic connection drawings	A38
XR	Cause and effect	A36
XS	Detail cross sectional drawings	
XT	Wiring diagrams	A37
XU	Loop diagram	A15
XX	Drawings - miscellaneous	
ZA	EDP documentation	

ANNEX E AREA CODES (NORMATIVE)

General

A facility may be divided into both areas, elements and/or levels.

Note that single facilities within a field should be defined in compliance with any applicable authoritative regulations.

Area code format

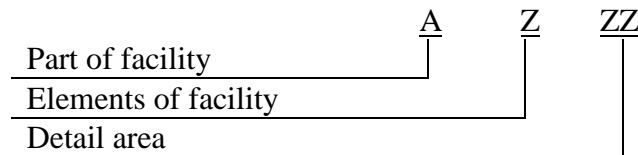

Part of facility

A single alphabetic character defines a part of a facility as indicated below. Remaining characters can be project/facility specific.

B	Bridges
C	Cellar Deck
D	Drilling
F	Flare
G	GBS
H	Helideck
J	Jacket
L	LQ
M	Module
P	Pipeline
R	Risers
S	Hull
T	Topsides
Z	Space between modules

Elements of facility

A single alphanumeric character defines an element within a part of a facility, e.g. a floor in a LQ or a level in the facility. It may be either a numerical or an alphabetical character according to project/facility specific requirements.

Detail area

Two alphanumerical characters define any details within an element, e.g.

- room nos. on a floor
- longship/crossship nos. in a ship/hull.
- module id + suffix for details

They may be either numerical or alphabetical characters according to project specific requirements.

Longship sections shall be coded from a defined aft-centre origo. Crossship sections shall be from midship with even numbers on starboard and uneven on port.

Examples:

H14F
Helideck level 1 , forth section in fire area

M21A
Second Module, level 1 in area A .

L216
LQ's second floor, room no. 16 .

GR19
GBS' riser shaft, section 19 .

TC23
Turret's level C, Long-ship section no. 2, crossship section no. 3 .

P11I
Pipeline weld expansion loop for wet gas-line to platform riser

ANNEX F ACCEPTANCE CODES (INFORMATIVE)

ACCEPTANCE CODE

An acceptance code may be assigned to supplier documents submitted for review and acceptance. The following codes may be used:

- Code 1: Accepted
- Code 2: Accepted with comments incorporated
- Code 3: Not accepted, revise and resubmit
- Code 4: Issued for information
- Code 5: Interface information as clouded is accepted and frozen

The assigned acceptance code may be shown on the document

.

ANNEX G PRODUCT SERVICE CODES , INCLUDING COLOR CODING (INFORMATIVE)

<i>Product Service</i>	<i>Description</i>	<i>Primary colour</i>	<i>Secondary colour</i>
AI	AIR INSTRUMENT	Light blue	White
AP	AIR PLANT	Light blue	White
BC	BULK CEMENT	Dark red	White
BL	CEMENT, LIQUID ADDITIVE	Dark red	Green
CB	CHEMICAL, BIOCIDES	Violet	Black
CC	CHEMICAL, CATALYST	Violet	
CD	CHEMICAL, SCALE INHIBITOR	Violet	Black
CE	CHEMICAL, DE-MULSIFIER OR DE-FOAMENT	Violet	Black
CF	CHEMICAL, SURFACE ACTIVE FLUID	Violet	
CG	CHEMICAL, GLYCOL	Violet	Orange
CH	CHEMICAL, AFFF	Safety red	Yellow
CJ	PH CONTROLLER		
CK	CORROSION INHIBITOR	Violet	
CM	CEMENT, HIGH/LOW PRESSURE	Dark red	Green
CN	CHEMICAL MUD ADDITIVE	Dark red	White
CO	CHEMICAL, OXYGEN SCAVANGER	Violet	Black
CP	CHEMICAL, POLYELECTROLYTE / FLOKKULANT	Violet	Black
CS	CHEMICAL, SODIUM HYPOCHLORITE SOLUTION	Violet	
CV	WAX INHIBITOR	Violet	Black
CW	CHEMICAL, GLYCOL/WATER (Rich Glycol to Regen.)	Violet	Orange
DC	DRAIN, CLOSED	Black	Blue
DM	DRAIN, MUD	Black	
DO	DRAIN, OPEN	Black	Yellow
DS	DRAIN, SEWER/SANITARY	Black	Green
DW	DRAIN, WATER/STORM	Black	Yellow
FC	COMPLETION FLUID HIGH/LOW PRESSURE	Dark red	White
FJ	FUEL, JET	Brown	Violet
GA	GAS, FIRE FIGHTING/CO2	Safety red	Silver gray
GF	GAS, FUEL	Yellow ochre	White
GI	GAS, INERT	Yellow ochre	Silver gray
GW	GAS, WASTE/FLUE	Yellow ochre	
MB	MUD, BULK/SOLID	Dark red	White
MH	MUD, HIGH PRESSURE	Dark red	Orange
MK	MUD, KILL	Dark red	Orange
ML	MUD, LOW PRESSURE	Dark red	White
OF	OIL, FUEL (Diesel Oil)	Brown	Yellow
OH	OIL, HYDRAULIC	Brown	Blue
OL	OIL, LUBRICATING	Brown	
OS	OIL, SEAL	Brown	
PB	PROCESS BLOW DOWN	Yellow ochre	
PL	PROCESS HYDROCARBONS LIQUID	Brown	White

PV	PROCESS HYDROCARBONS VAPOUR	Yellow ochre	
PT	PROCESS TWO PHASE	Brown	
PW	PRODUCED WATER	Green	Brown
SP	STEAM, PROCESS	Silver grey	Green
SU	STEAM, UTILITY/PLANT	Silver grey	Green
VA	VENT, ATMOSPHERIC	Yellow ochre	Silver grey
VF	VENT, FLARE	Yellow ochre	
WA	WATER, SEA ANTIQUIFICATION	Green	Yellow
WB	WATER, SEA, BALLAST/GROUT	Green	Yellow
WC	WATER, FRESH/GLYCOL - COOLING MEDIUM	Violet	Orange
WD	WATER, FRESH, POTABLE	Green	Blue
WF	WATER, SEA, FIRE FIGHTING	Safety red	White
WG	WATER, GROUTING SYSTEMS	Green	Yellow
WH	WATER, FRESH/GLYCOL - HEATING MEDIUM	Violet	Orange
WI	WATER, SEA, INJECTION	Green	Yellow
WJ	WATER, JET	Green	Yellow
WP	WATER, FRESH, RAW	Green	Green
WQ	WATER, FRESH, HOT (CLOSED CIRCUIT)	Green	Violet
WS	WATER, SEA	Green	White
WT	BASE OIL		

ANNEX H EXAMPLES (INFORMATIVE)

H.1 Document coding

PROJECT NAME					
LOGO					
Rev.	Date	Reason for issue	Prep.	Checked	Accepted
Company name (logo)		Title		Responsible party	
				No. of sheets	
	Doc.type code	Area code	Document number		Rev. code
			Project code-Orig. code-Discipl. code-Seq. no.		
Contract no.	System				